

wldn

**WIRD  
IHNEN  
GEFALLEN!**

3D VISUALISIERUNG





Sie kommen gerne schnell auf den Punkt? Wir auch. Jeder einzelne von uns bietet ein breites Leistungsspektrum, wir sind **spezialisierte Generalisten**. Und wir haben verstanden, dass eine reine Auflistung unserer Fähigkeiten und Kenntnisse nicht ausreicht. Auf den nächsten Seiten geben wir Ihnen daher die Bausteine in die Hand. Mit diesen visuellen Lösungsvorschlägen können sie dann Ihrer Kreativität freien Lauf lassen.

Wir sind keine „Werbeagentur in der Cloud“, keine ausgelagerte Marketingabteilung, keine Kampagnenmacher. Wir machen 3D. Und das verdammt gut.

### WLDN | White Label Design Network?

Wir bleiben auf Wunsch anonym („White Label“) und halten uns im Hintergrund, unsere externe Lösung ist Ihre interne. Unsere Angebote sind fair und unser Timing stimmt. Vertrauen und Zuverlässigkeit ist alles.

WLDN ist keine Agentur und kein Unternehmen. WLDN ist auch keine Personenvereinigung, Körperschaft, GbR, OHG, GmbH, Genossenschaft oder Ähnliches. Wir sind alle voneinander unabhängige Einzelanbieter, die bei Ihren Dienstleistungen ausschließlich mit Einzelvertragsbeziehungen arbeiten. Mit entsprechend klar abgegrenzten Eigen- und Einzelverantwortlichkeiten.



Andreas | Dipl.-Des.  
3D-GENERALIST



Peer | 3D Designer  
3D-GENERALIST



Markus | Dipl.-Des.  
3D-GENERALIST



Martin | 3D Designer  
3D-GENERALIST



Isabel | Dipl.-Des.  
ILLUSTRATION, KONZEPTION



Janine | Fachwirtin  
CONTROLLING, ACCOUNTING



Nicole | Dipl.-Ing.  
ARCHITEKTUR, SZENOGRAFIE



Johannes | Dipl.-Des.  
PRINT, GENERALIST



Connie | Dipl.-Ökon.  
MEDIZIN, KONZEPTION



Bernd | 3D Designer  
MEDIZIN, 3D-GENERALIST



Thomas | Cutter  
SCHNITT, INTERAKTIVE MEDIEN



Horst | Musiker  
MUSIK, SOUND FX

# wldn PRODUCT

Ihr Produkt verändert häufig sein Erscheinungsbild? Eine Produktreihe hat immer die gleiche Form aber eine andere Farbe, Etikett oder Inhalt? Sie benötigen für Ihre Datenbank oder Anzeigenvorlage immer exakt die gleiche Platzierung, Ausleuchtung und Farbgebung? Sie möchten ein Produkt oder Produktvarianten zeigen, die es noch gar nicht gibt?

Reden Sie mit uns – und dann ab ins virtuelle Fotostudio: **Volle Kontrolle.**



wldn PRODUCT



WLDN PRODUCT



# PRODUCT IN CONTEXT

Ihr Produkt erklärt sich nur im Kontext richtig gut? Gegebenenfalls bauen wir auch ein ganzes Haus drumherum: **Voller Durchblick.**

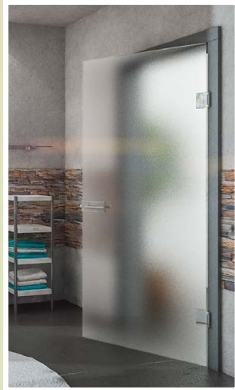



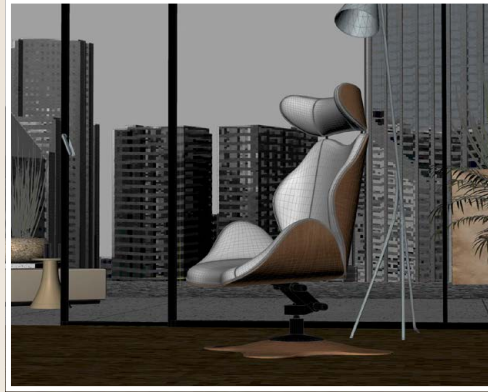



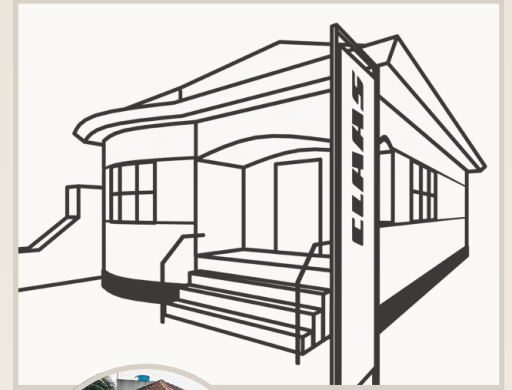
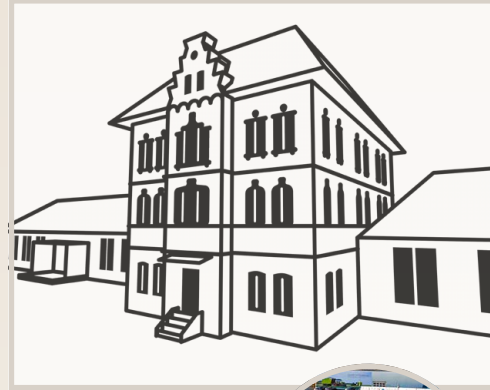
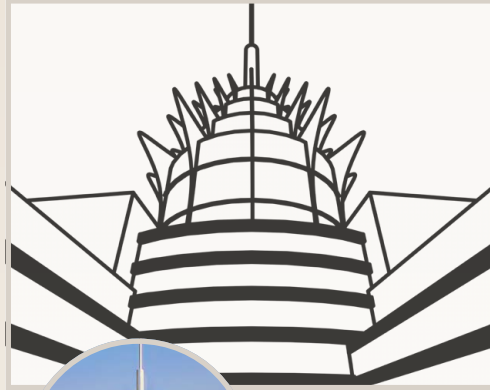
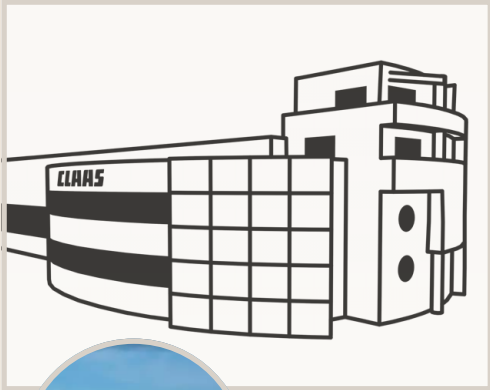

Farmers

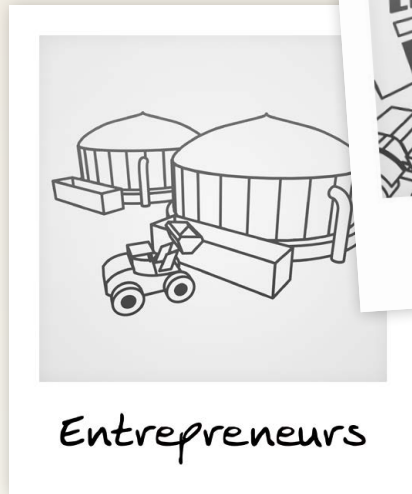

Entrepreneurs



Dealers



Cooperatives



Contractors

# wldn TECHNICAL

Ein technischer Ablauf muss erklärt werden? Sie brauchen exakte oder auch stilisierte Abbildungen, großflächige oder sehr kleinteilige Darstellungen? Sie benötigen Querschnitte, Explosionszeichnungen und Visualisierungen aus allen Perspektiven? Geht alles. Zur Erklärung nehmen wir auch gerne die Dimension Zeit hinzu und erstellen eine Animation. Damit Ihr Produkt für sich sprechen kann: **Klare Darstellung.**

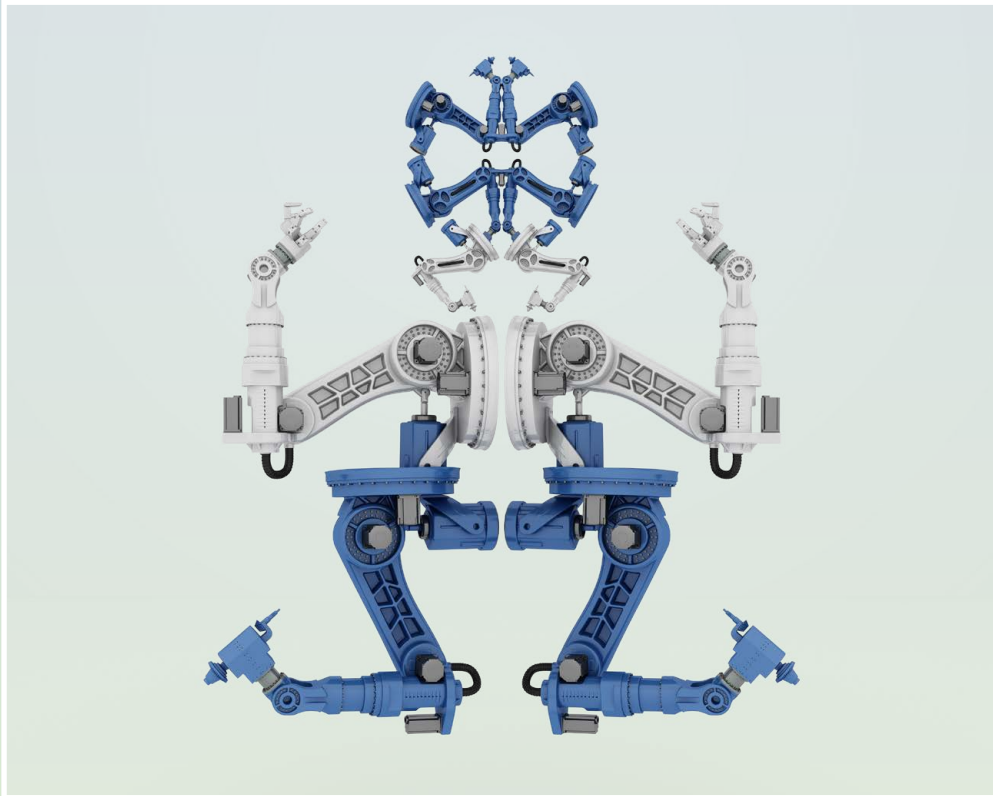
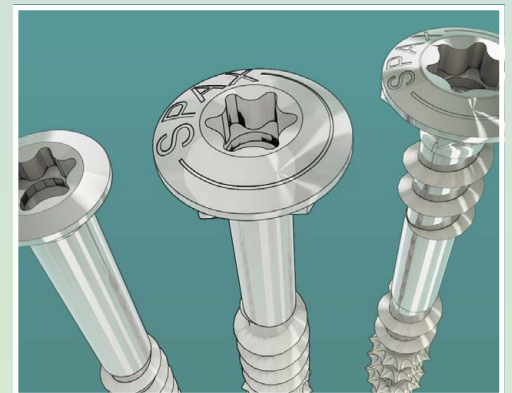
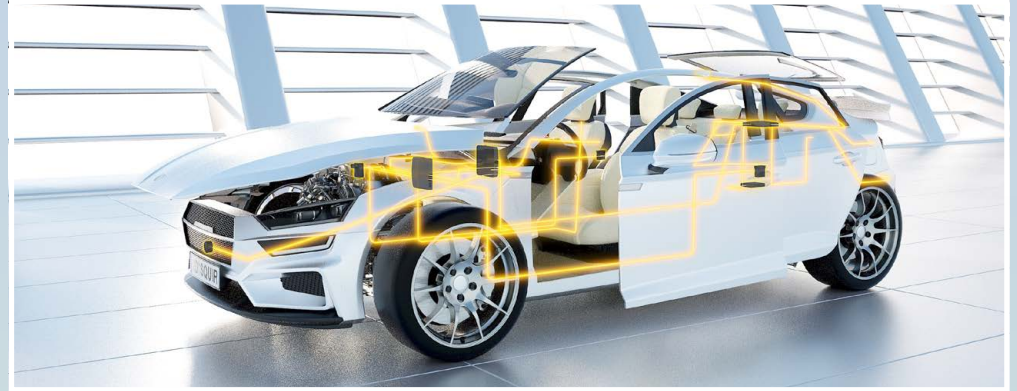

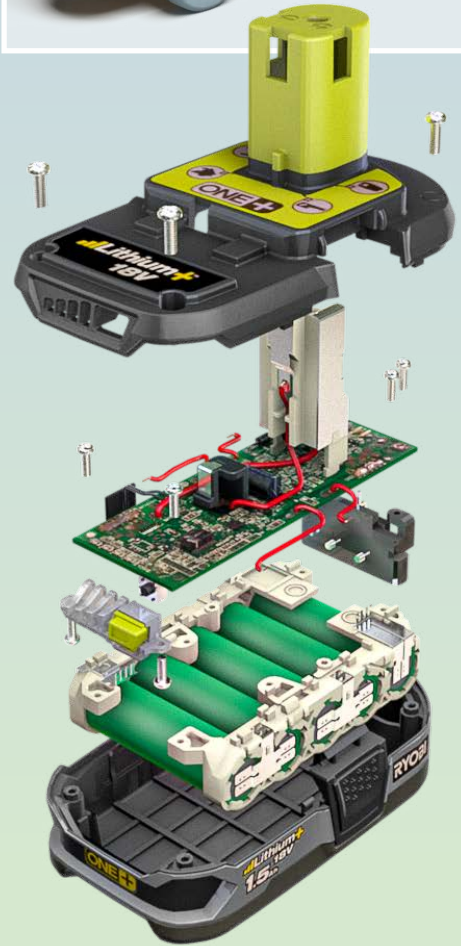
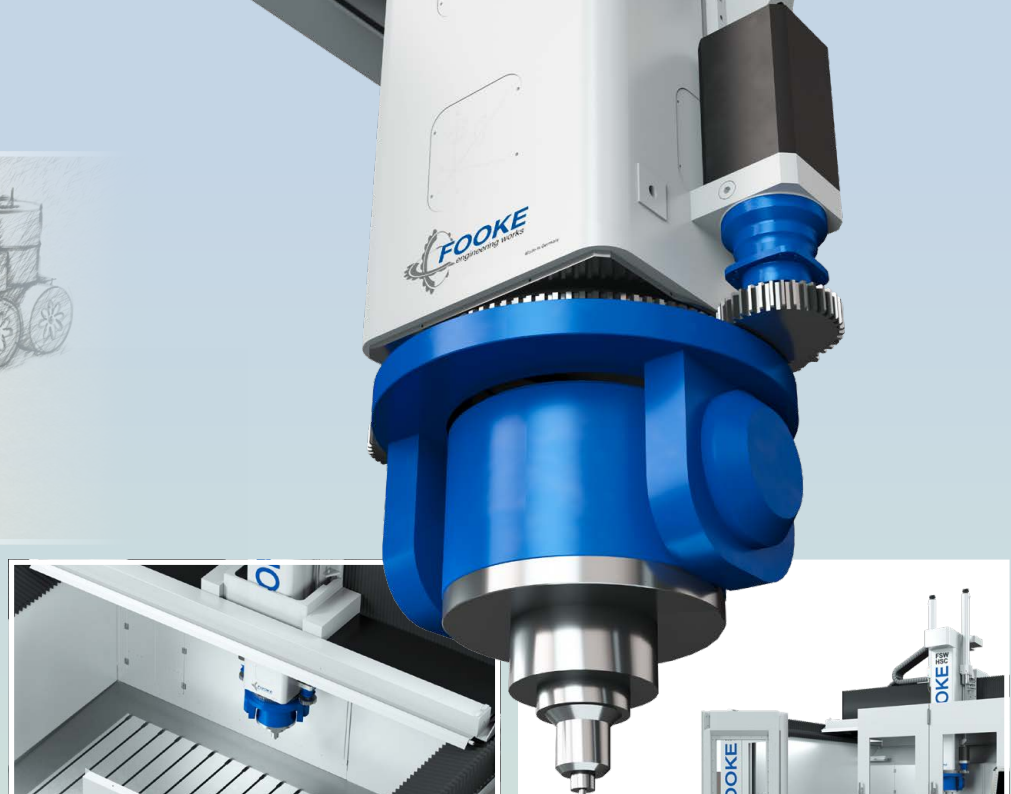
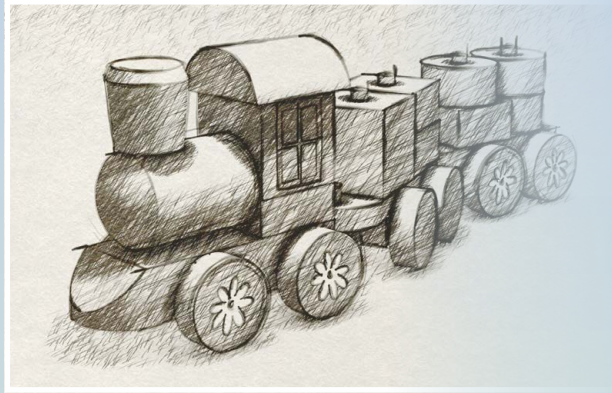



# REDUCE COMPLEXITY

Oftmals muss man Komplexität deutlich reduzieren – um die Dinge im Ganzen verständlich darstellen zu können: **Einfach machen.**

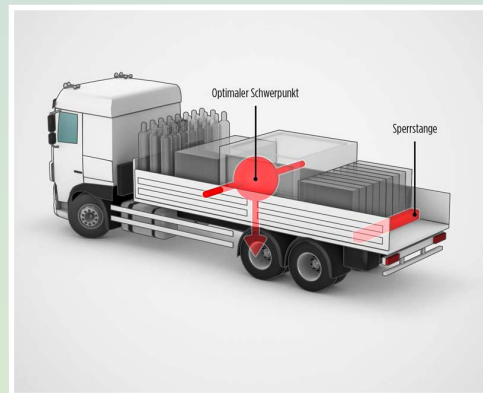
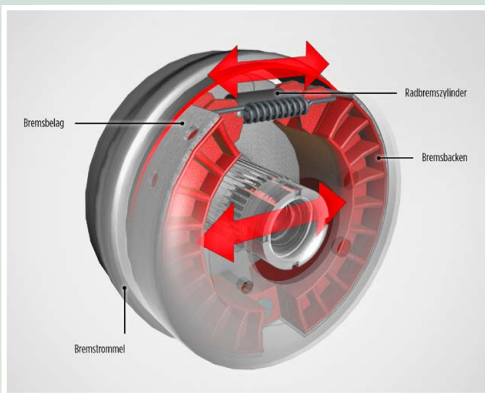
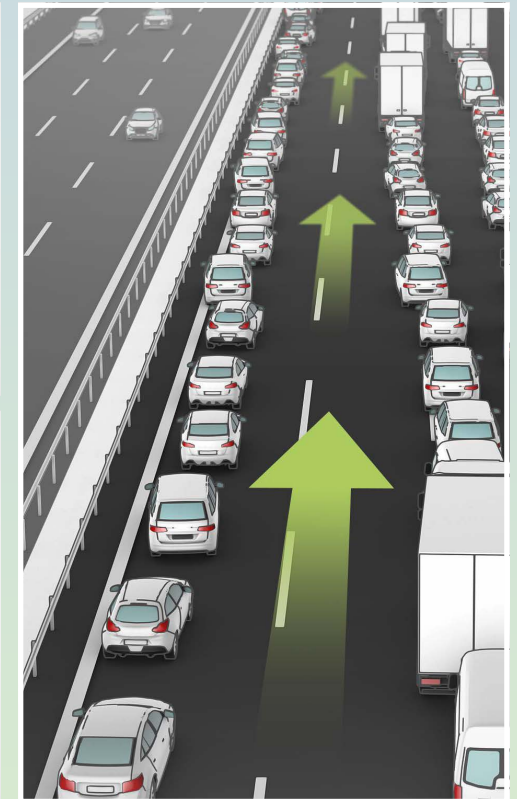
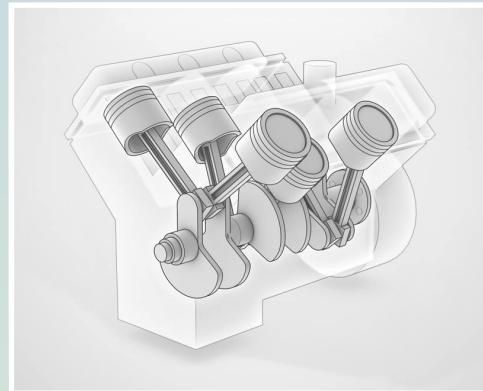
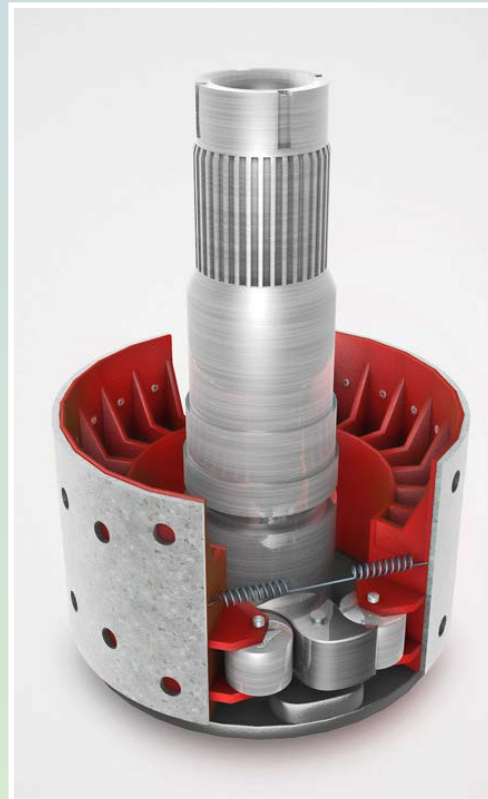
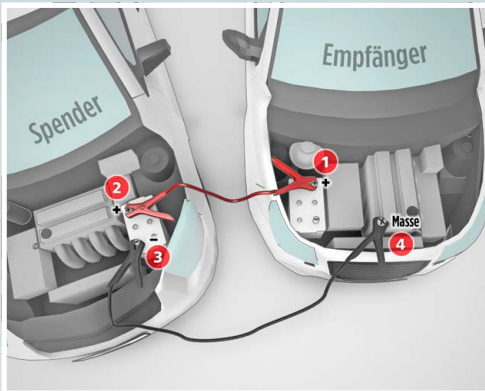
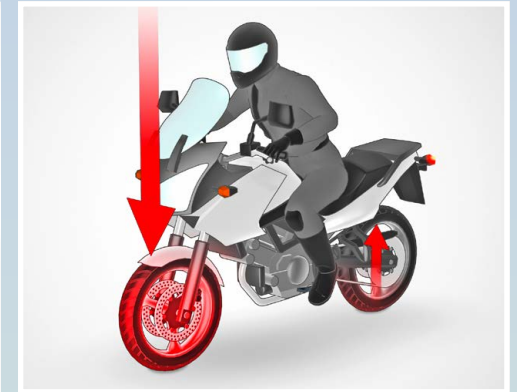
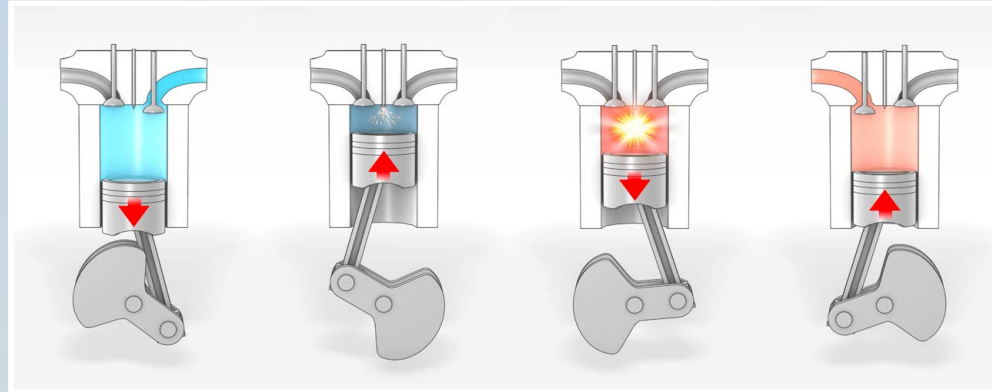

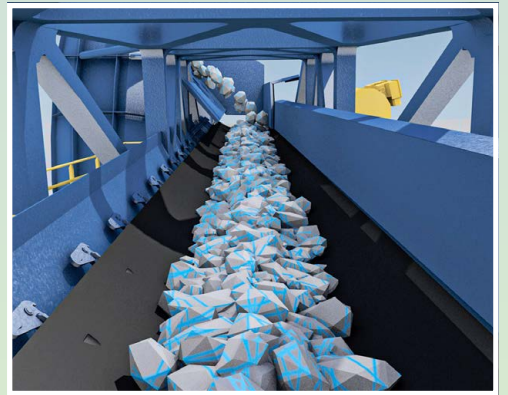
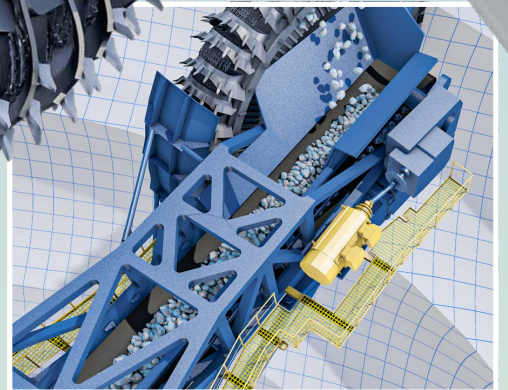
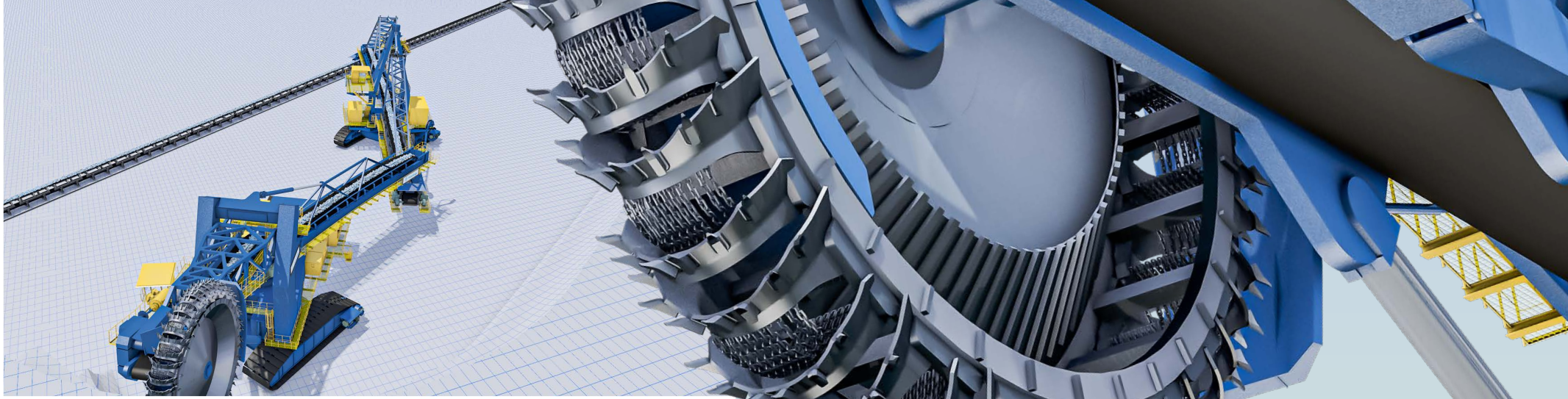



foto: eosandy.com



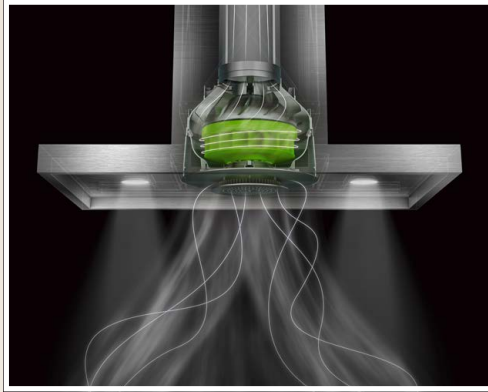
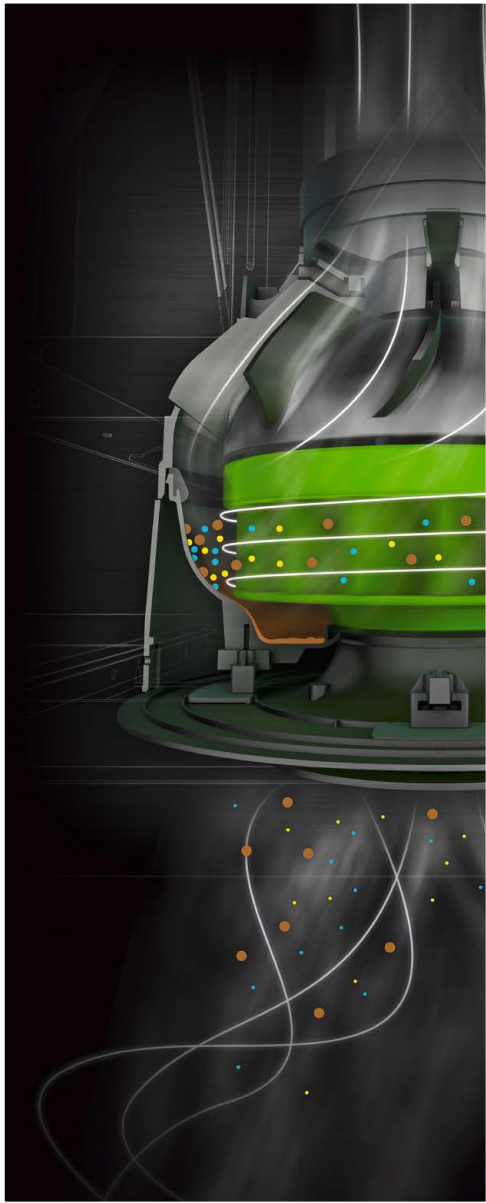
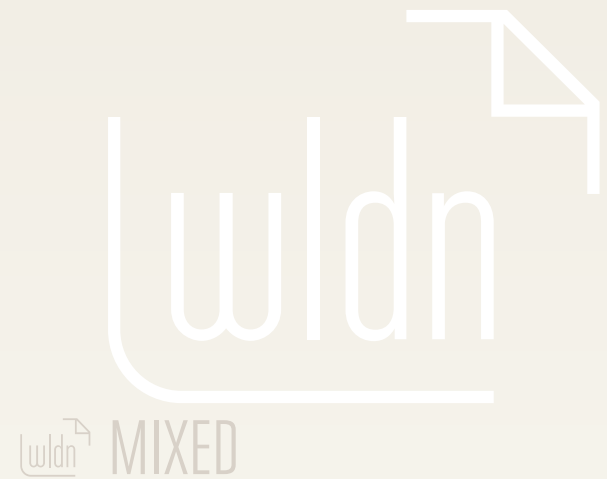
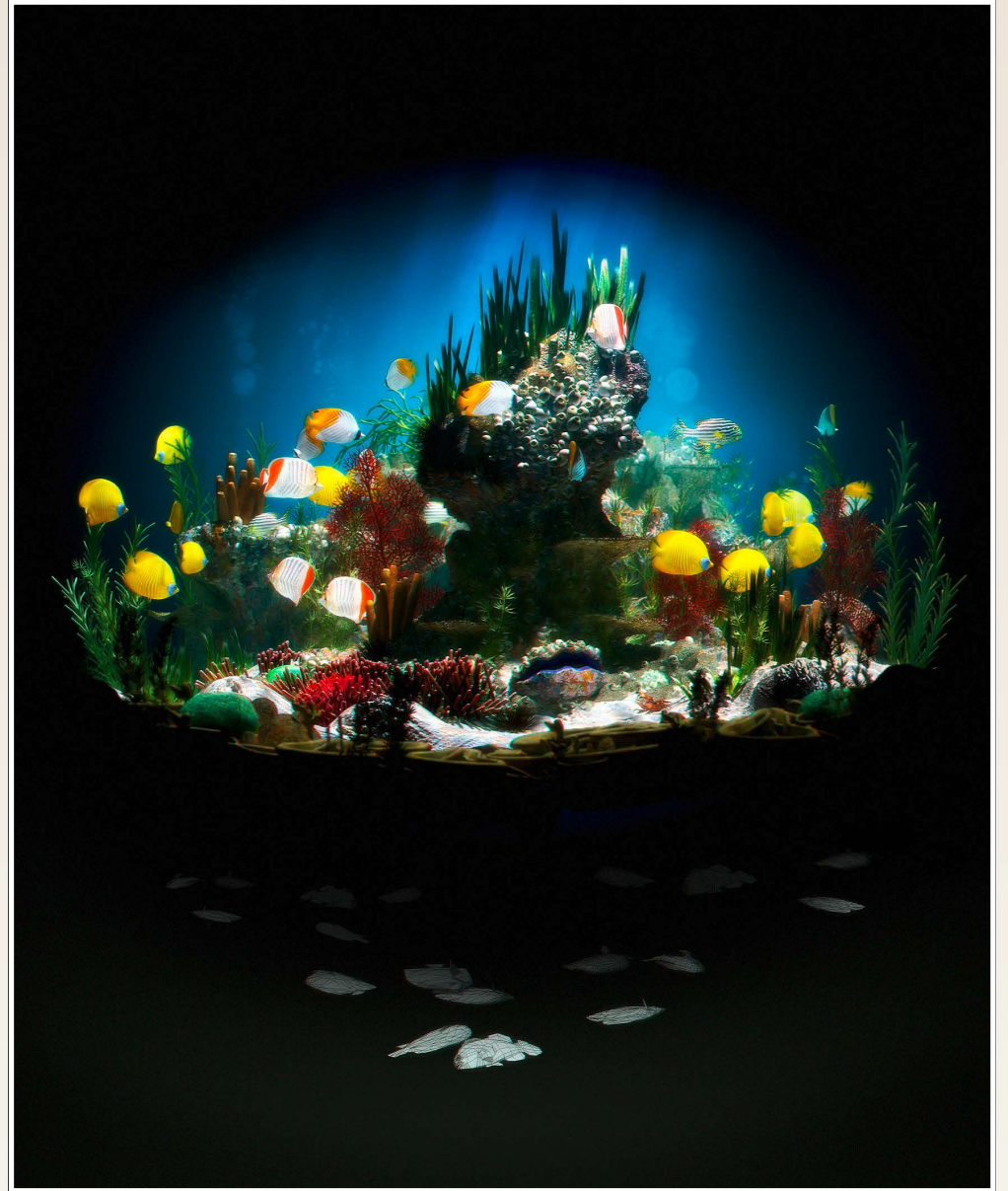
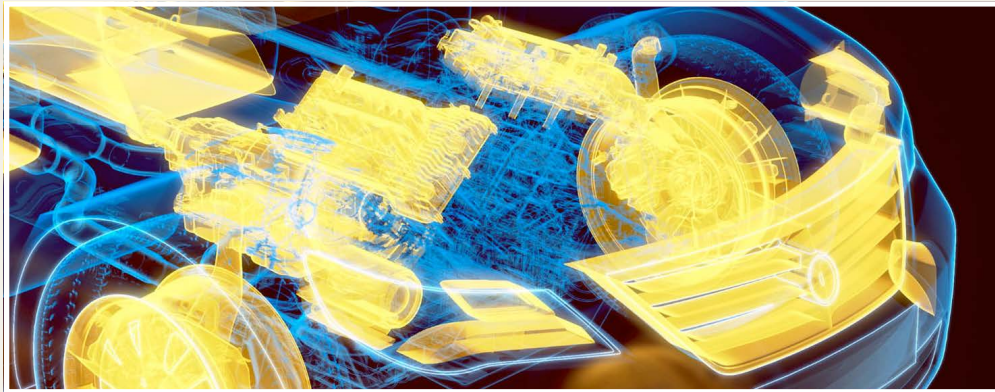

# wldn MEDICAL

Sie benötigen Visualisierungen aus dem Mikrokosmos? Stilisierte oder fotorealistische Darstellungen aus dem medizinischen oder biologischen Bereich? Sie wollen Wirkung oder Abläufe von Prozessen zeigen, die sich fotografisch, filmisch oder illustrativ nur schwer realisieren lassen?

Mitten aus dem Leben: Mit Erfahrung und Expertise an Bord. Damit nicht nur alles schön wird – sondern auch schön richtig. **Mit viel Herz.**

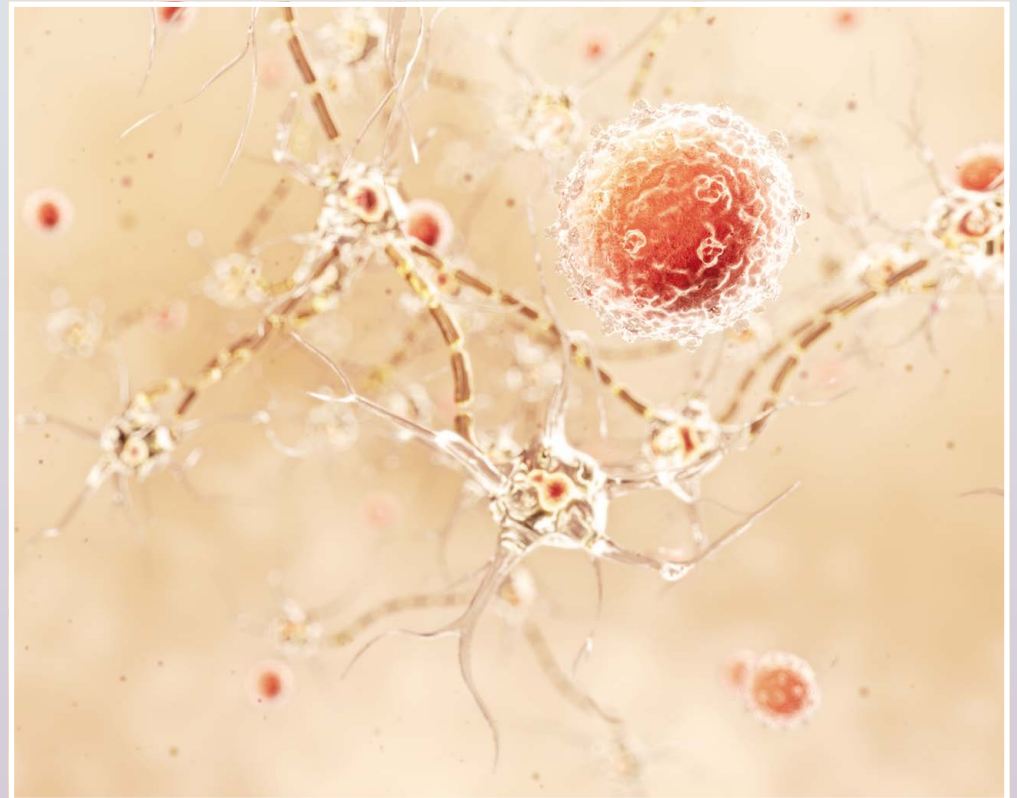
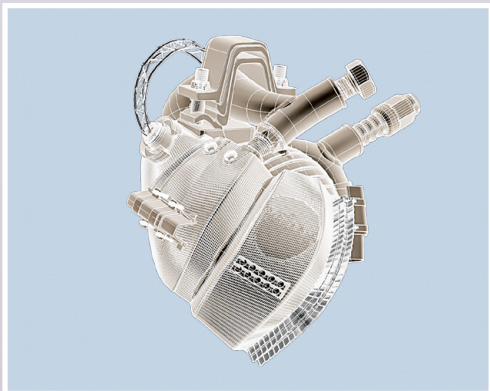
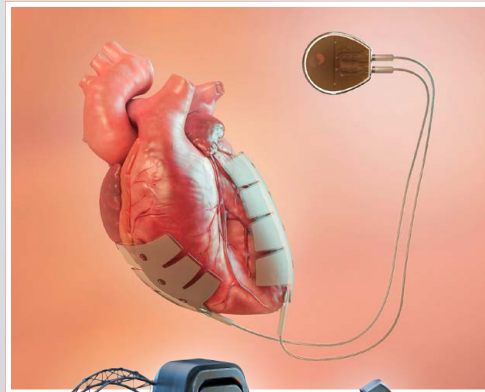
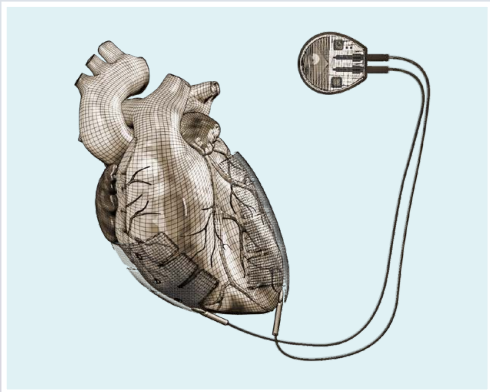
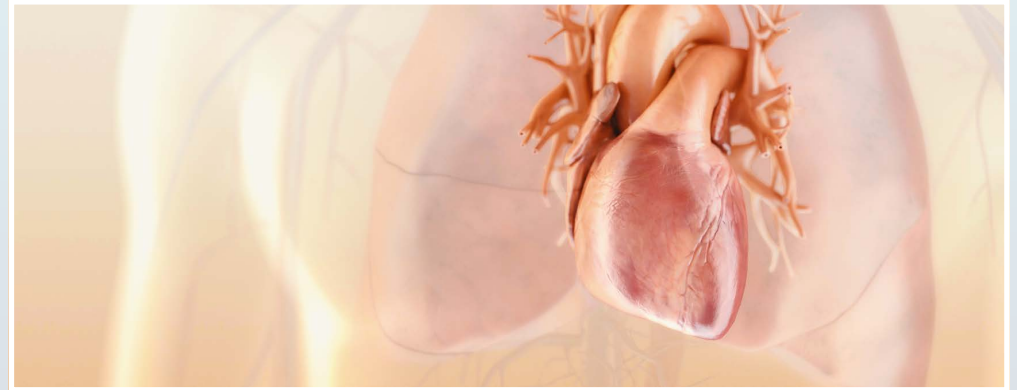



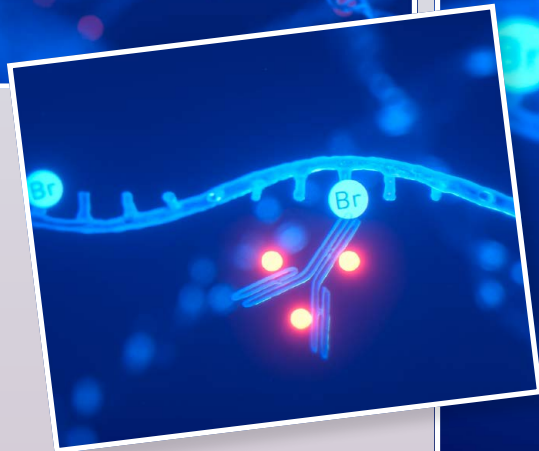
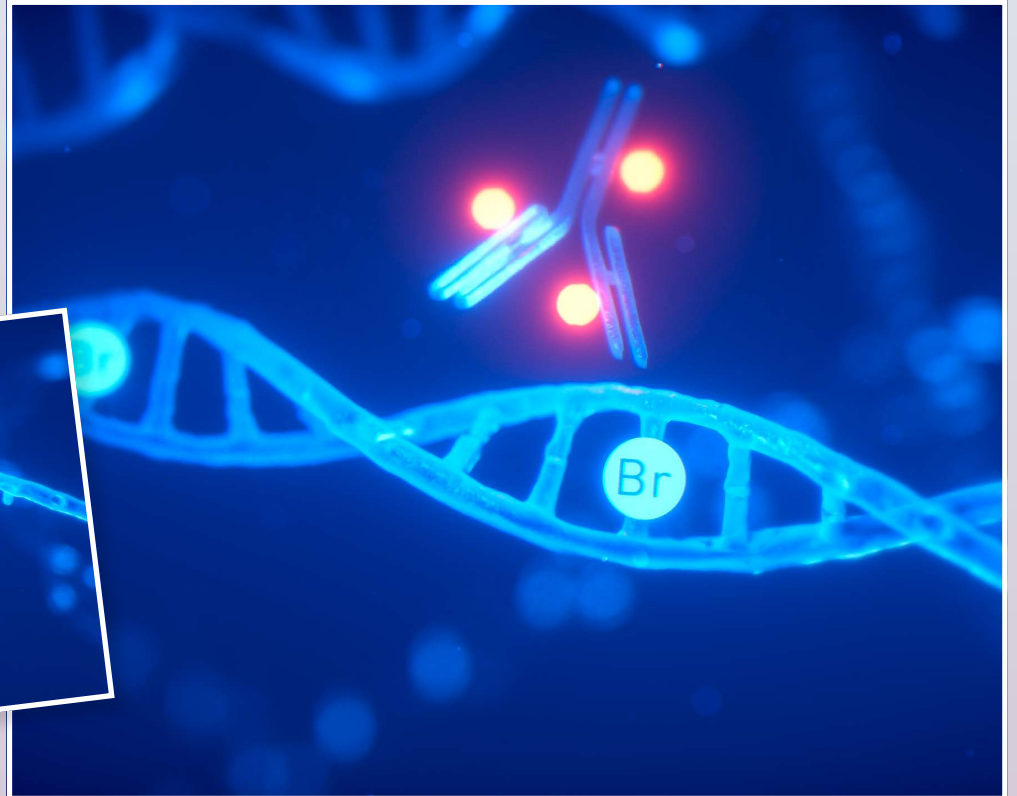
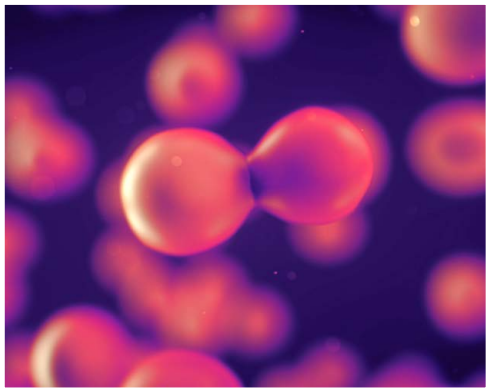
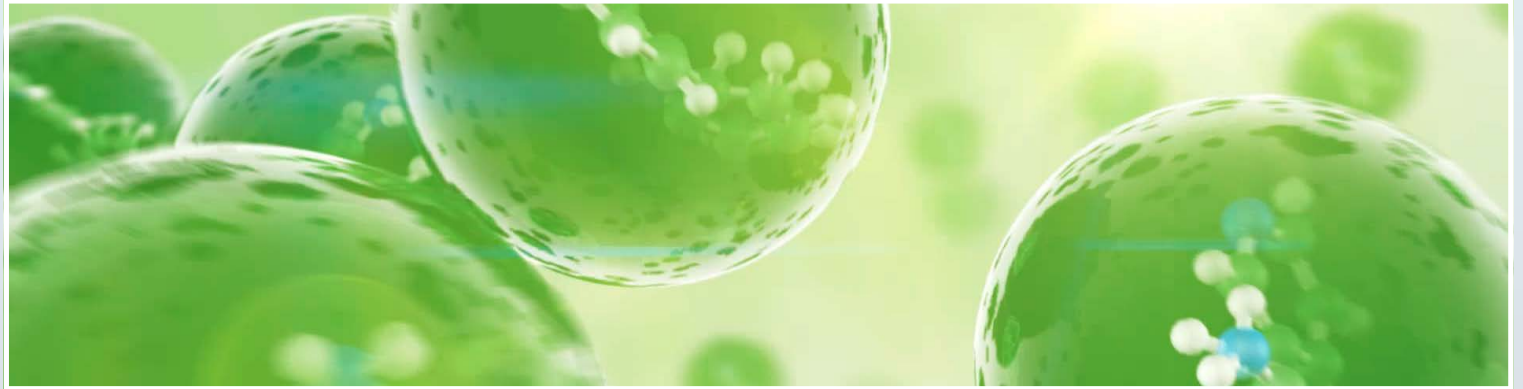
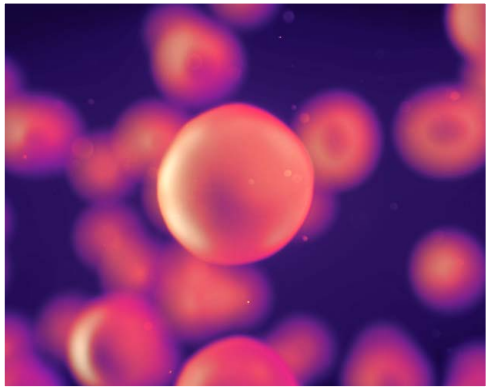



# INSIDE JOB

Schicht für Schicht auf visuell angenehme Weise anschaulich machen, was man anders nicht zeigen kann – oder anders nicht zeigen möchte: **Innenansichten.**

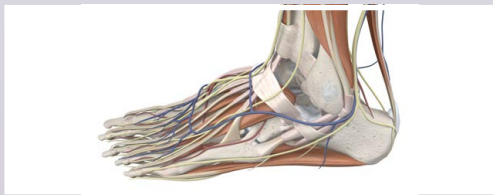
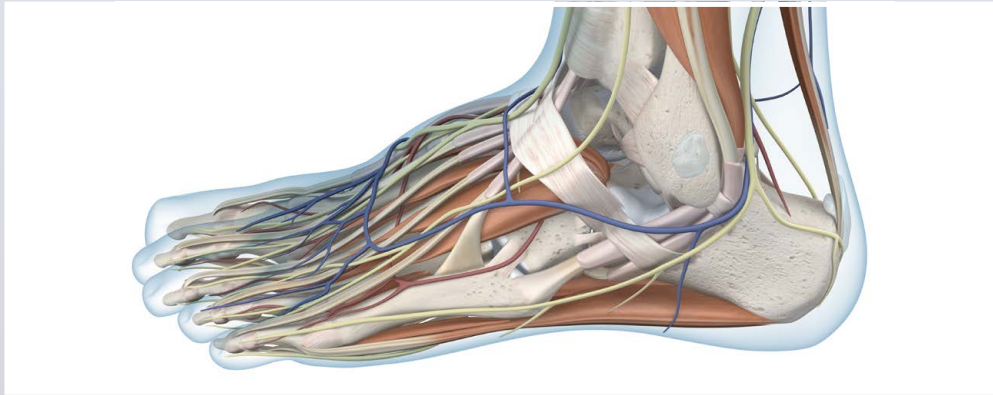
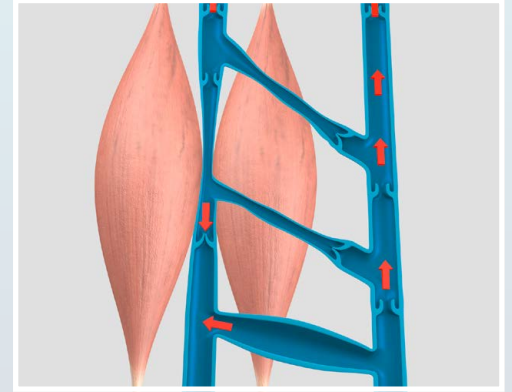
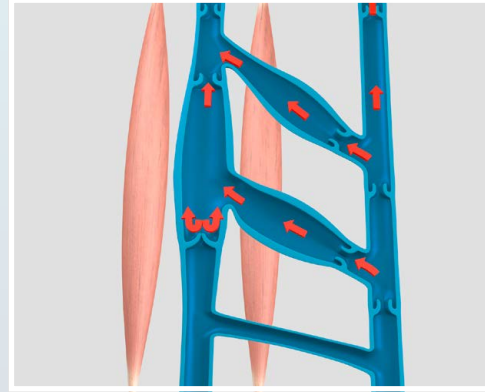
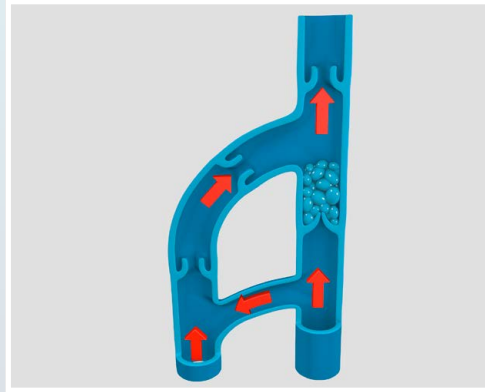

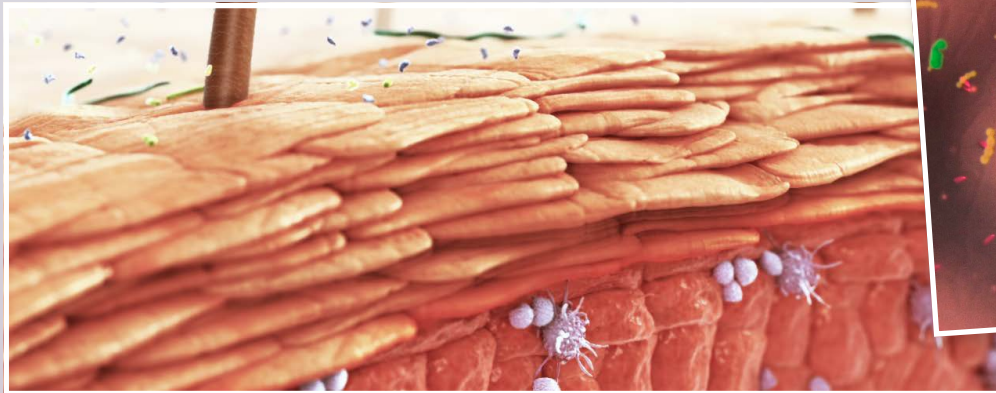
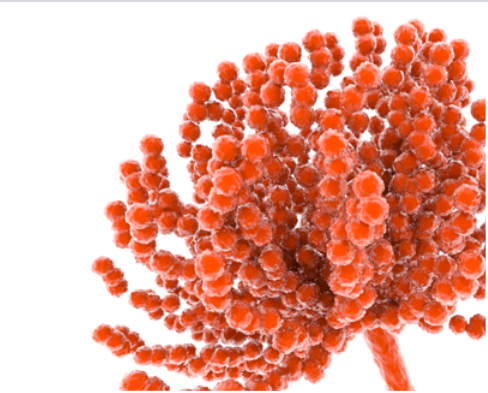
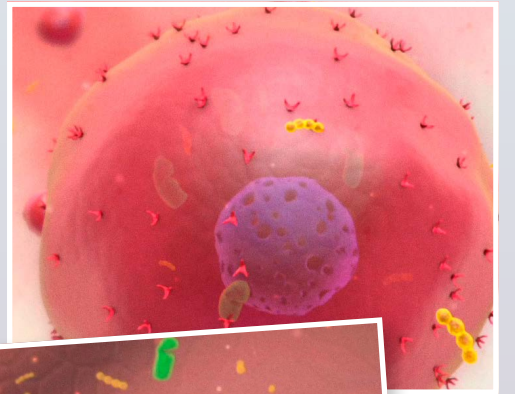
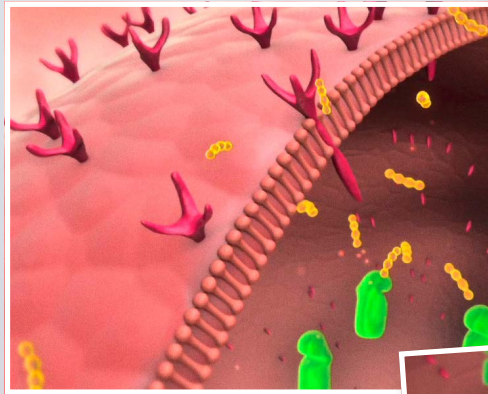
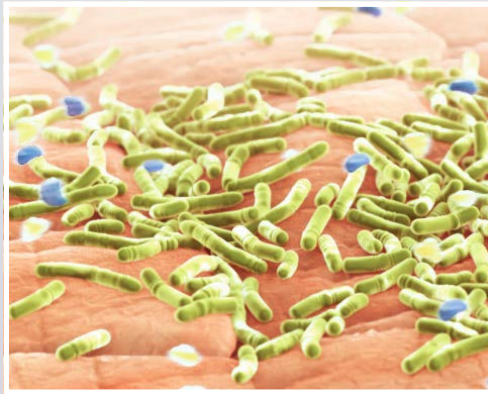
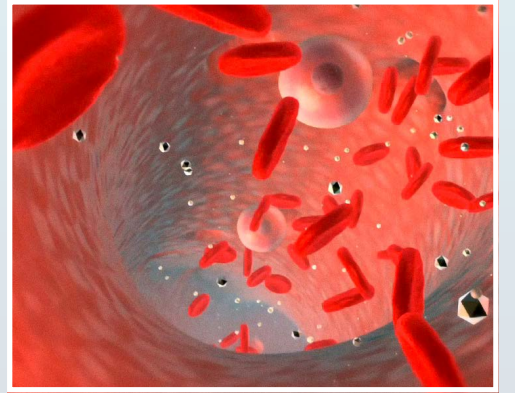
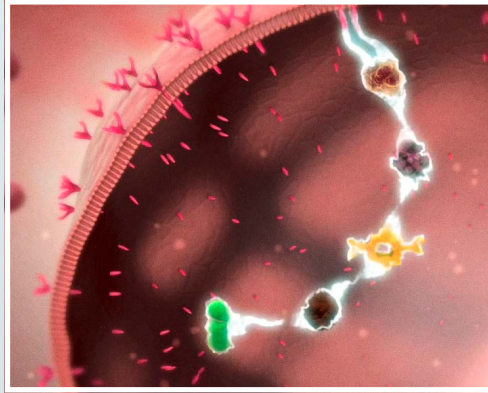
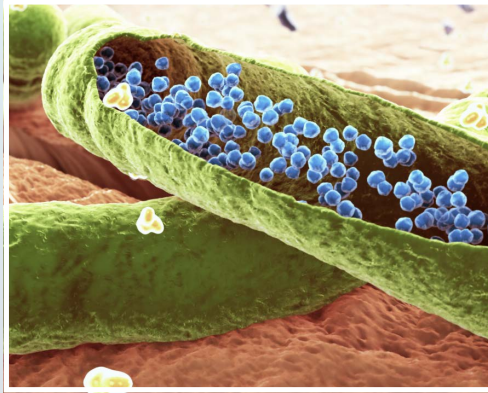
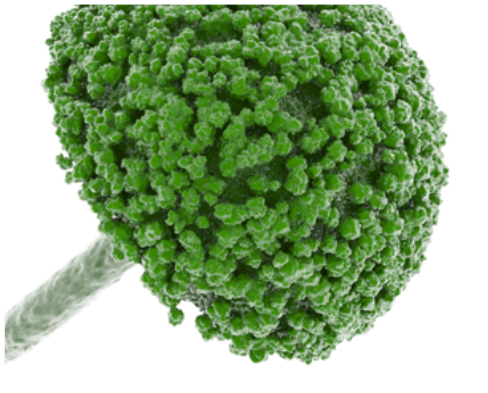

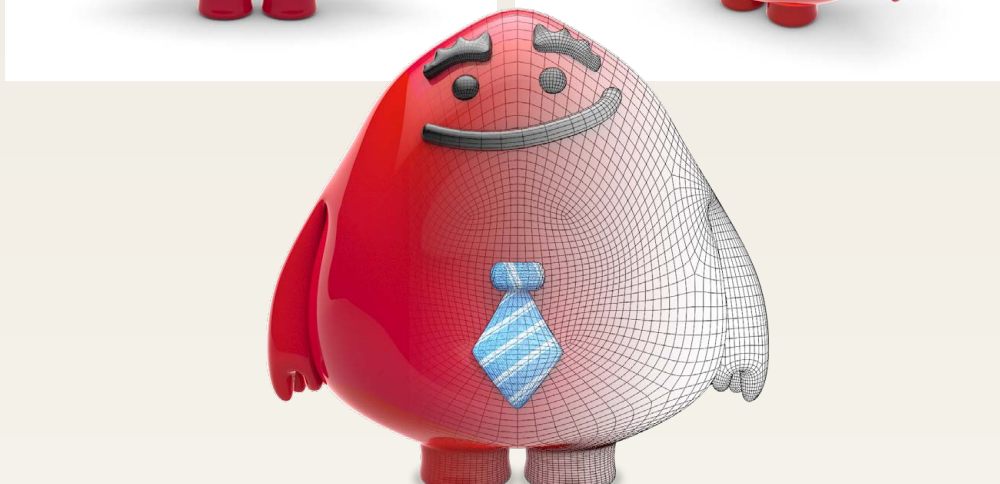
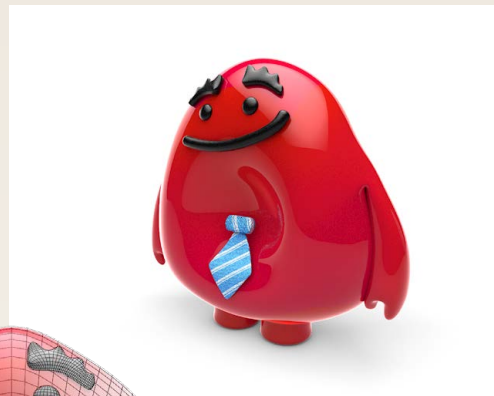
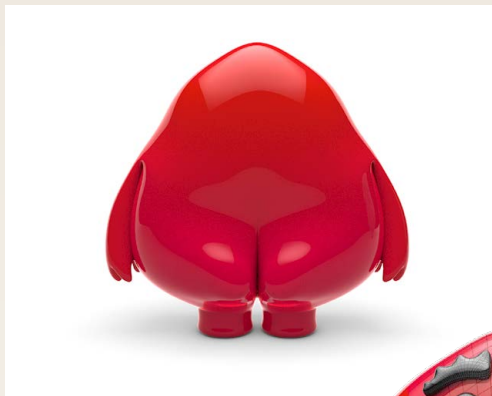
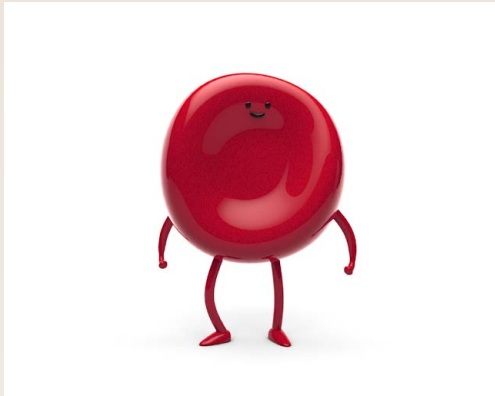

wldn MIXED

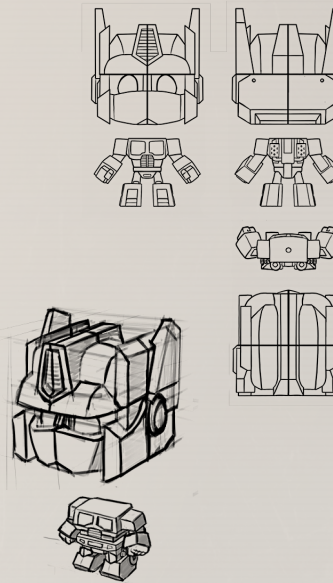

# wldn ARCH VIZ

Ihr Objekt ist noch nicht gebaut? Sie möchten alles ins rechte Licht setzen aber das Wetter spielt nicht mit? Ihrem Loft fehlt noch Farbe und Einrichtung und den Interessenten die Fantasie? Oder benötigen Sie visuelle Argumente für die Finanzierung oder Genehmigung einer Immobilie? Natürlich gibt es das auch bewegt oder interaktiv, als Film oder Rundgang. Wir bauen Ihre Zukunft. **Voll virtuell.**

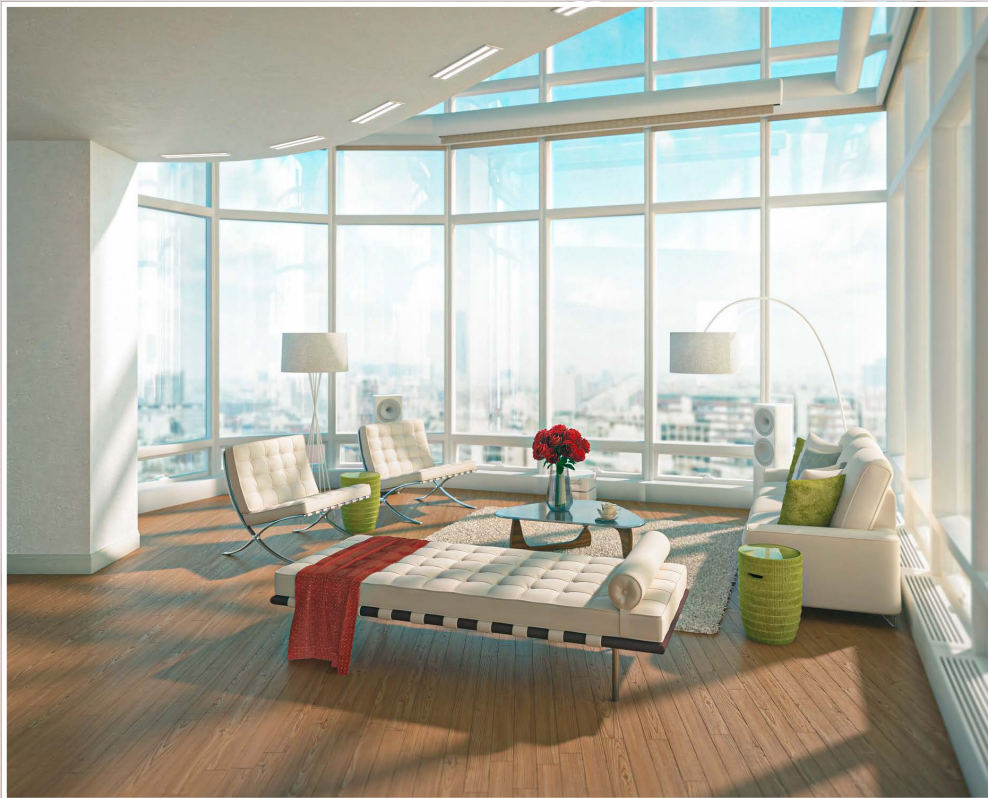
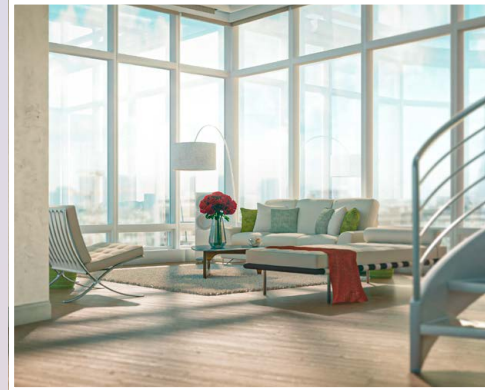



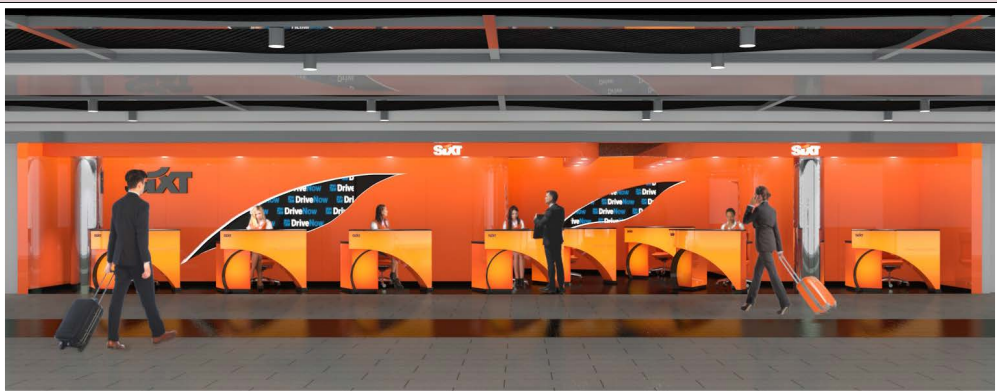
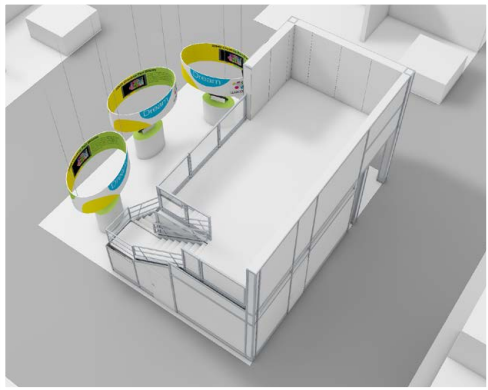





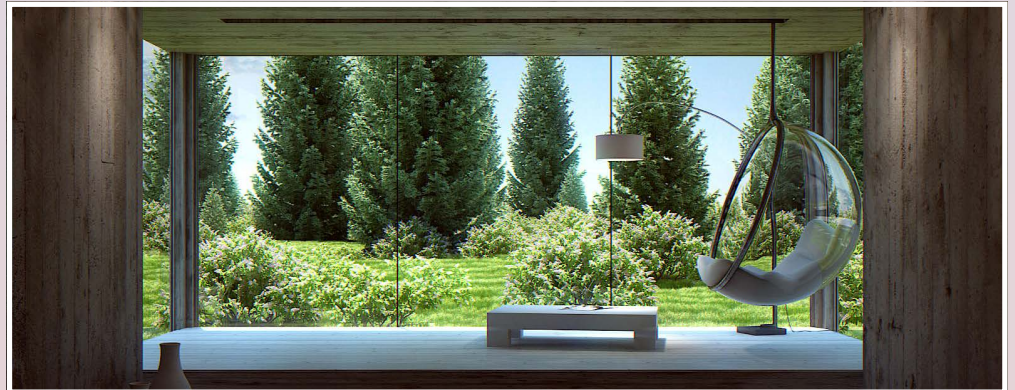



## CONTACT

Wir hoffen, jetzt haben Sie eine Idee. Wenn nicht – anrufen, anregen lassen oder einfach direkt anfragen. Wir sind nur einen Tastendruck entfernt und freuen uns auf das spannende Gespräch mit Ihnen.

# CONTACT@WLDN.DE

Besuchen Sie unsere Website:

**[www.wldn.de](http://www.wldn.de)**

Oder rufen Sie einfach an:

Andreas Raskopp  
*Alpen*  
**+49 2802 894 96 56**  
**+49 151 275 254 35**

Peer Brauner  
*Oberhausen*  
**+49 177 685 33 37**

Markus Ceh  
*Mülheim a. d. Ruhr*  
**+49 151 432 590 06**

Martin Ernst  
*Bochum*  
**+ 49 176 227 041 27**

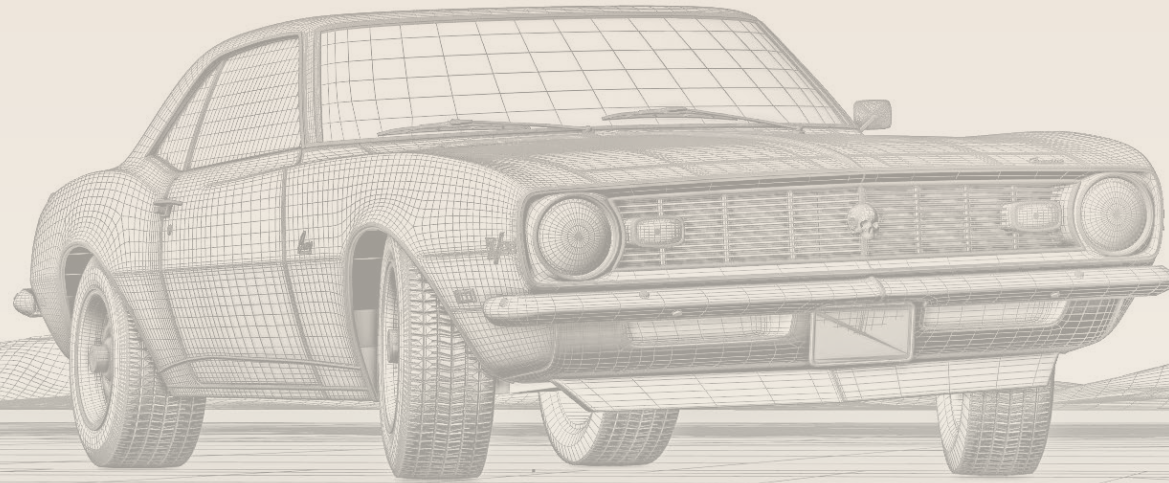

[CONTACT@WLDN.DE](mailto:CONTACT@WLDN.DE)